

Two Post Lift

CO 2.30E3



Parts Breakdown

English

EDITION

5th edition 2005-12-21
D1 3626EL5-GB05

© SLIFT HEBEZEUGE GMBH & Co. KG

All rights reserved. Any reproductions of this document, partial or complete, are only allowed with prior consent of SLIFT GmbH & Co. KG.

All rights reserved in cases of patent granting or registration of design.

The contents of this edition have been checked with great care. However, errors cannot be fully excluded. Please contact SLIFT should you find errors of any kind.

These instructions are intended for users with previous knowledge in the field of automotive vehicle service lifts.

Subject to technical change without notice.

MANUFACTURER

SLIFT Hebezeuge GmbH & Co. KG
Daimlerstraße 16
D-75233 Tiefenbronn

Phone: +49 (0) 7234 6070
Fax: +49 (0) 7234 60729

Internet: <http://www.slift.de>
E-mail: vertrieb@slift.de

SERVICE

SLIFT Hebezeuge GmbH & Co. KG
Daimlerstraße 16
D-75233 Tiefenbronn

Service: +49 (0) 7234 60776
 +49 (0) 7234 60777
 +49 (0) 7234 60778
Fax: +49 (0) 7234 60729

CONTENTS

1	CO 2.30E3	1
1.1	Cable Guide.....	1
1.2	Support Disk	2
1.3	Operating Column	3
1.4	Column	9
1.5	General View	15

When ordering spare parts please indicate:



- ◆ Serial number
- ◆ Model
- ◆ Accessory equipment
- ◆ Year of manufacture

For electrical components see wiring diagram supplied with the lift.

1 CO 2.30E3

1.1 Cable Guide

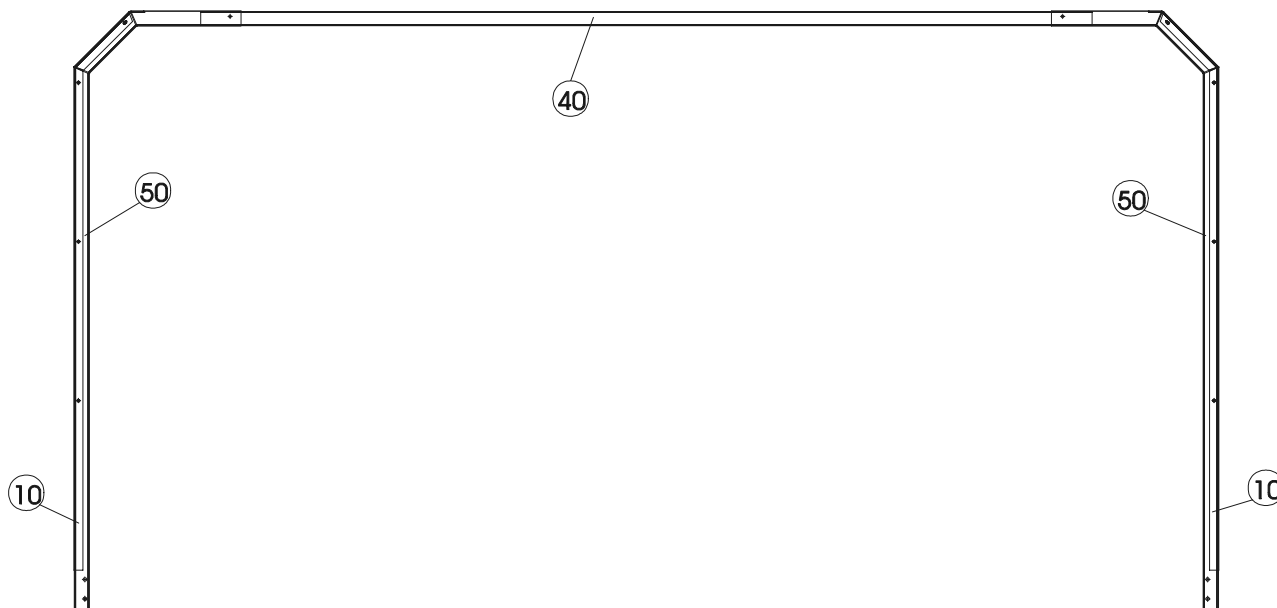

Item	Part #	Description	Specification
10	23000018	Cable Channel Cover	
40	23000017	Cable Channel	
50	23000019	Cable Channel Body	

1.2 Support Disk

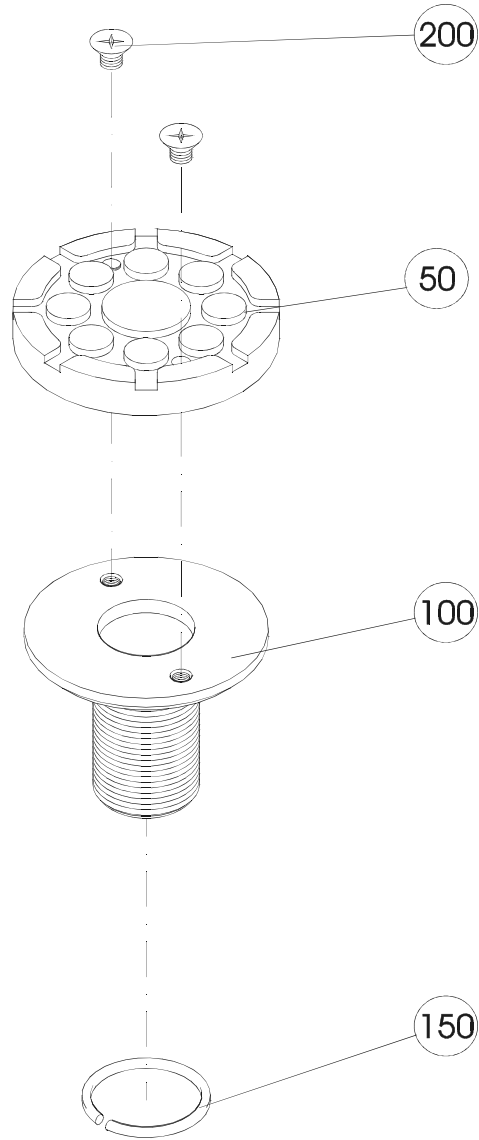

Item	Part #	Description	Specification
50	17 2023	Rubber Pad	Ø120
100	03 28 16710	Support Disk	
150	22 7993 045	Snap Ring	A45
200	22 7991 08012 1	Countersunk Screw	M8x12-8.8

1.3 Operating Column

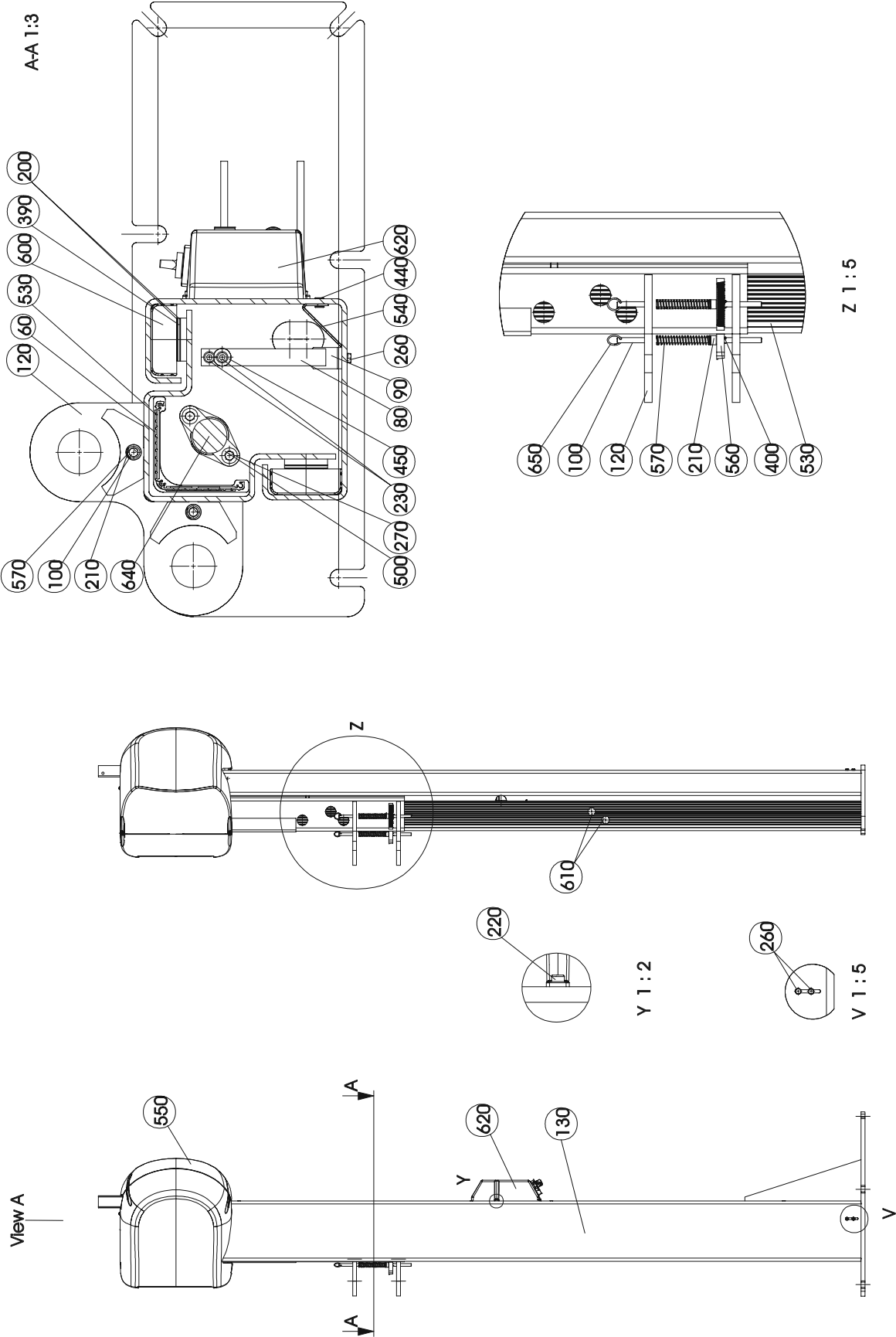

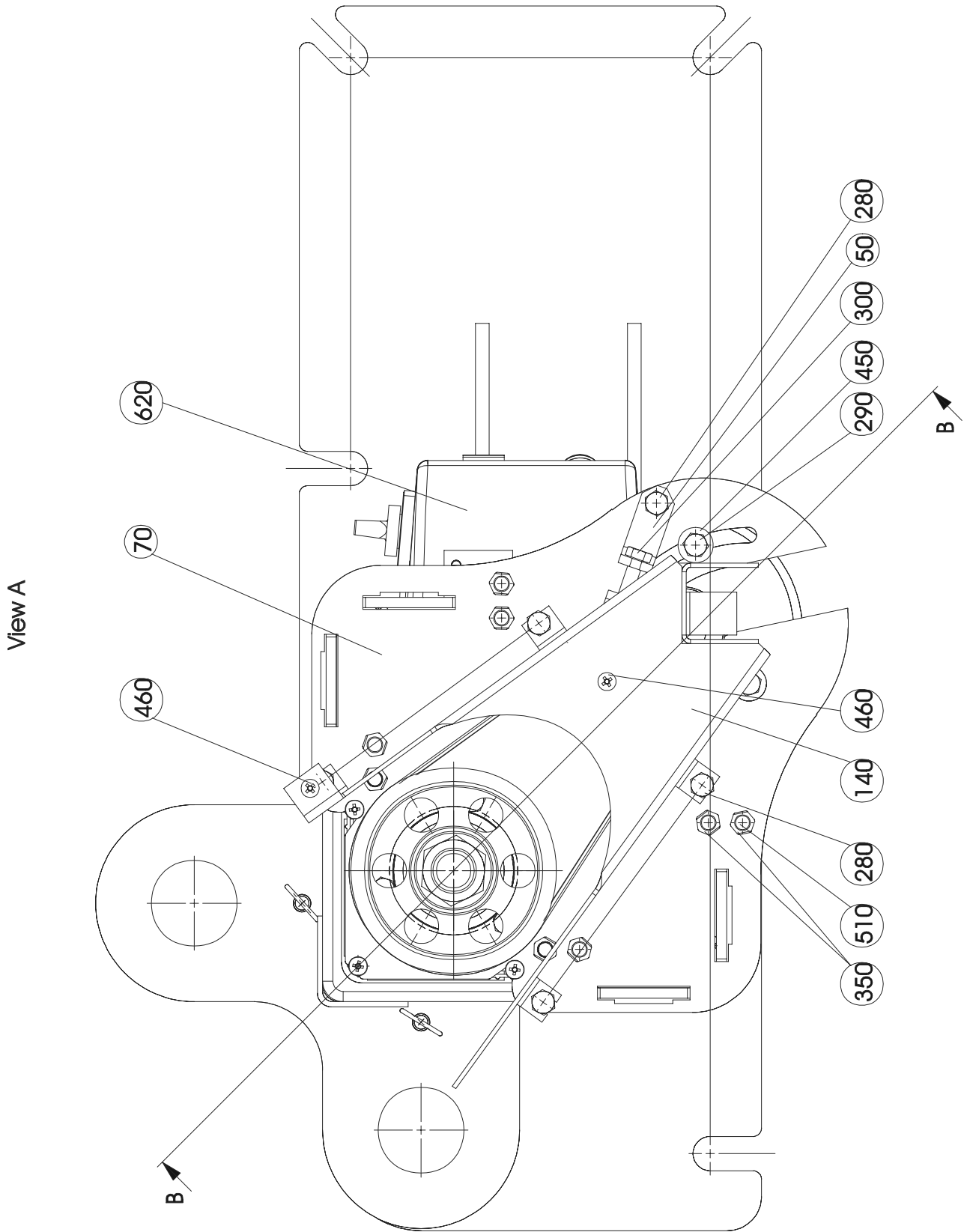

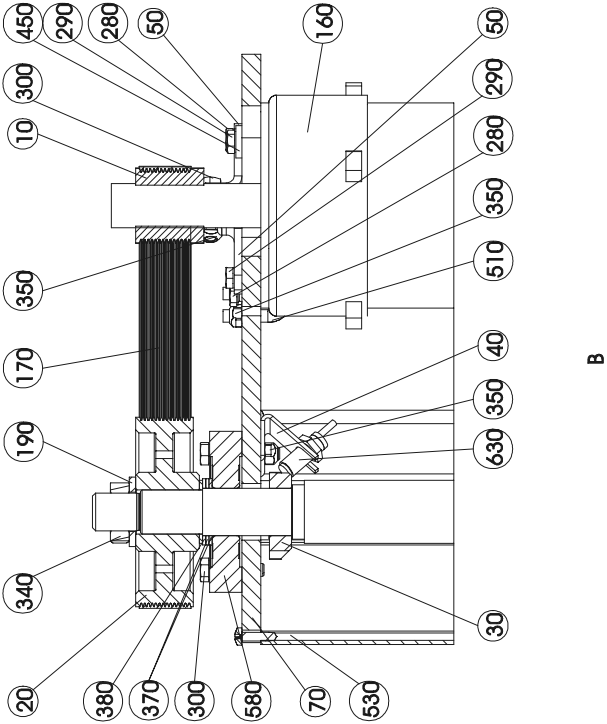
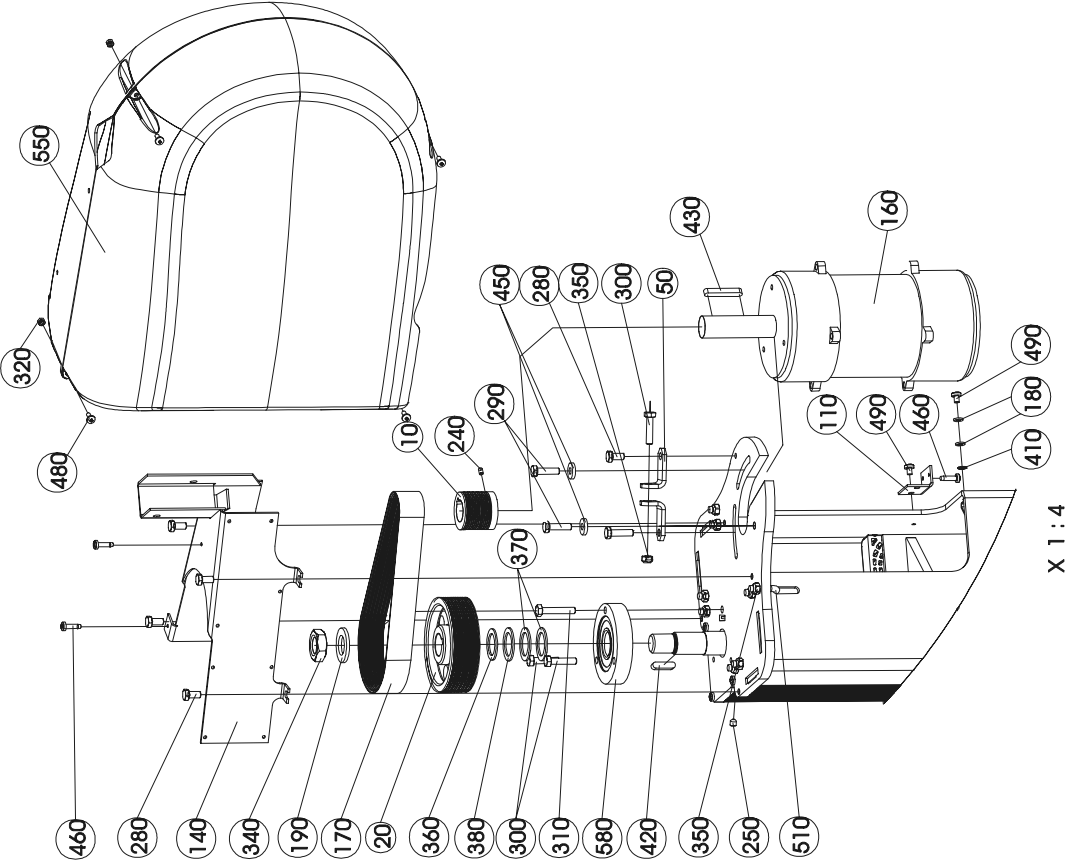

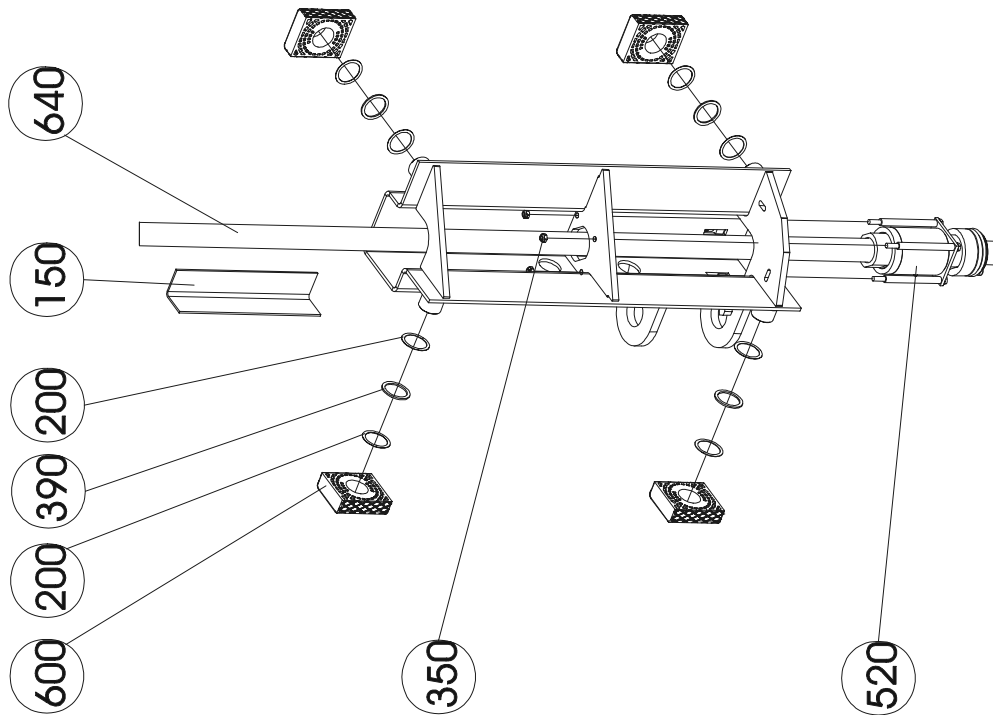
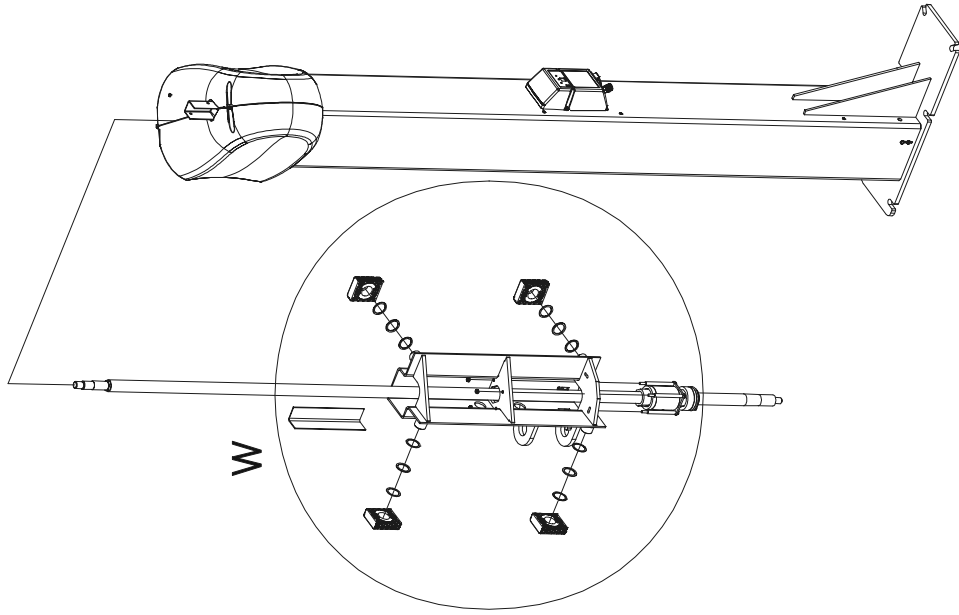

W 1 : 10

Item	Part #	Description	Specification
10	02 47 5240	Pulley	Rd. 50 44 lg.
20	02 47 5245	Pulley	Rd. 120 41 lg.
30	02 47 5270	Pulse Generator	
40	02 47 5290	Angle	
50	020470 00001800	Belt Tensioner	Sh. 70x20x5
60	020470 00001	Protective Insert	
70	020470 00006500	Motor Plate	Sh. 288x288x12
80	020470 00007000	Leaf Spring	
90	020470 00013700	Angle	Sh. 77x25x2.5
100	020470 00014400	Latch Release Rod	Rd. 10 280 lg.
110	020470 00014500	Angle	Sh. 57x40x2.5
120	030470 00004400	Carriage	
130	030470 00007200	Operating Column	
140	030470 00007700	Holder	
150	17 3076	Sponge Rubber Plate	285x100x5
160	20 7066 5	Motor CO 2.30E3	2.4 kW
170	20 9652	Ribbed V-Belt	PJ660; 14 Ribs, Poly V
180	22 0125 06 1	Washer	A6.4
190	22 0125 24 1	Washer	A25
200	22 0137 5040 5	Wave Spring Washer	
210	22 0705 10 1	Slide	A10
220	22 0912 06008 1	Allen Screw	M6x8-8.8
230	22 0912 08025 1	Allen Screw	M8x25-8.8
240	22 0914 05008	Threaded Pin	M5x8-45H
250	22 0914 08008	Threaded Pin	M8x8-45H
260	22 0933 06012 1	Hex Head Cap Screw	M6x12-8.8
270	22 0933 06020 1	Hex Head Cap Screw	M6x20-8.8
280	22 0933 08016 1	Hex Head Cap Screw	M8x16-8.8
290	22 0933 08030 1	Hex Head Cap Screw	M8x30-8.8
300	22 0933 08035 1	Hex Head Cap Screw	M8x35-8.8
310	22 0933 08045 1	Hex Head Cap Screw	M8x45-8.8
320	22 0934 05 1	Hex Nut	M5-8
330	51 3072	Proximity Switch, Inductive	M12 / 2 mm / Cable Length: 3.5 m
340	22 0934 2420 1	Hex Nut	M24x2-8
350	22 0985 08 1	Hex Nut	M8-04
360	22 0988 284020	Shim Ring	28x40x2
370	22 0988 304220	Shim Ring	30x42x2
380	22 0988 304225	Shim Ring	30x42x2.5
390	22 0988 405025	Shim Ring	40x50x2.5
400	22 1481 03016	Dowel Pin	3x16
410	22 6798 064 1	Serrated Washer	A6.4
420	22 6885 080730	Feather Key	A8x7x30
430	22 6885 080750	Feather Key	A8x7x50
440	22 7337 05016	Blind Rivet	A5x16
450	22 7349 08 1	Washer	8.4
460	22 7504 04819 1	Self-Drilling Screw	4.8x19

CO 2.30E3

470	22 7504 05522 1	Self-Drilling Screw	5.5x22
480	22 7985 05012 1	Flat Head Screw	M5x12-4.8-H
490	22 7985 06008 1	Flat Head Screw	M6x8-4.8-H
500	22 9021 06 1	Washer	A6.4
510	23 0170	Fastening Bow	M8-8.8
520	030470 00016500	Load and Safety Nut Assembly	
530	23000011	Screw Drive Cover	
540	23000025	Cable Cover	
550	23000024	Cover Hood CO 2.30E3	
560	23000015	Gear Segment	
570	23000026	Pressure Spring	
580	24 8015 000	Flange Bearing	BE 72-30
590	24 8016 000	Flange Bearing igubal	
600	31 6068	Slider Block	10x83x30
610	31 5050	Cap Plug	
620	53 2644	Control Unit CO 2.30E3	
630	51 3073	Proximity Switch, Inductive	M12 / 2 mm / Cable Length: 0.5 m
640	23 4770 001	Screw Drive	
650	23000032	Key Ring	

1.4 Column

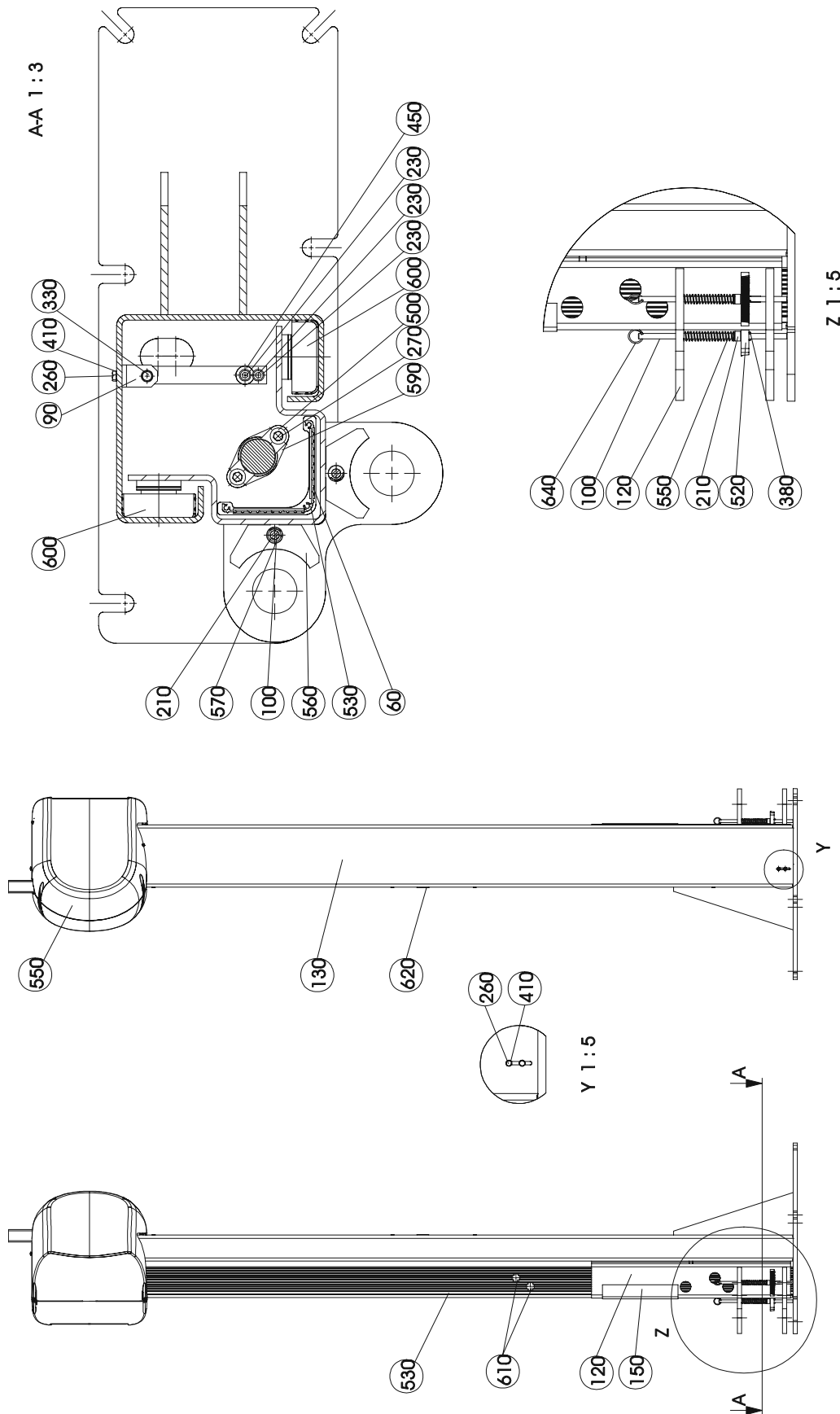

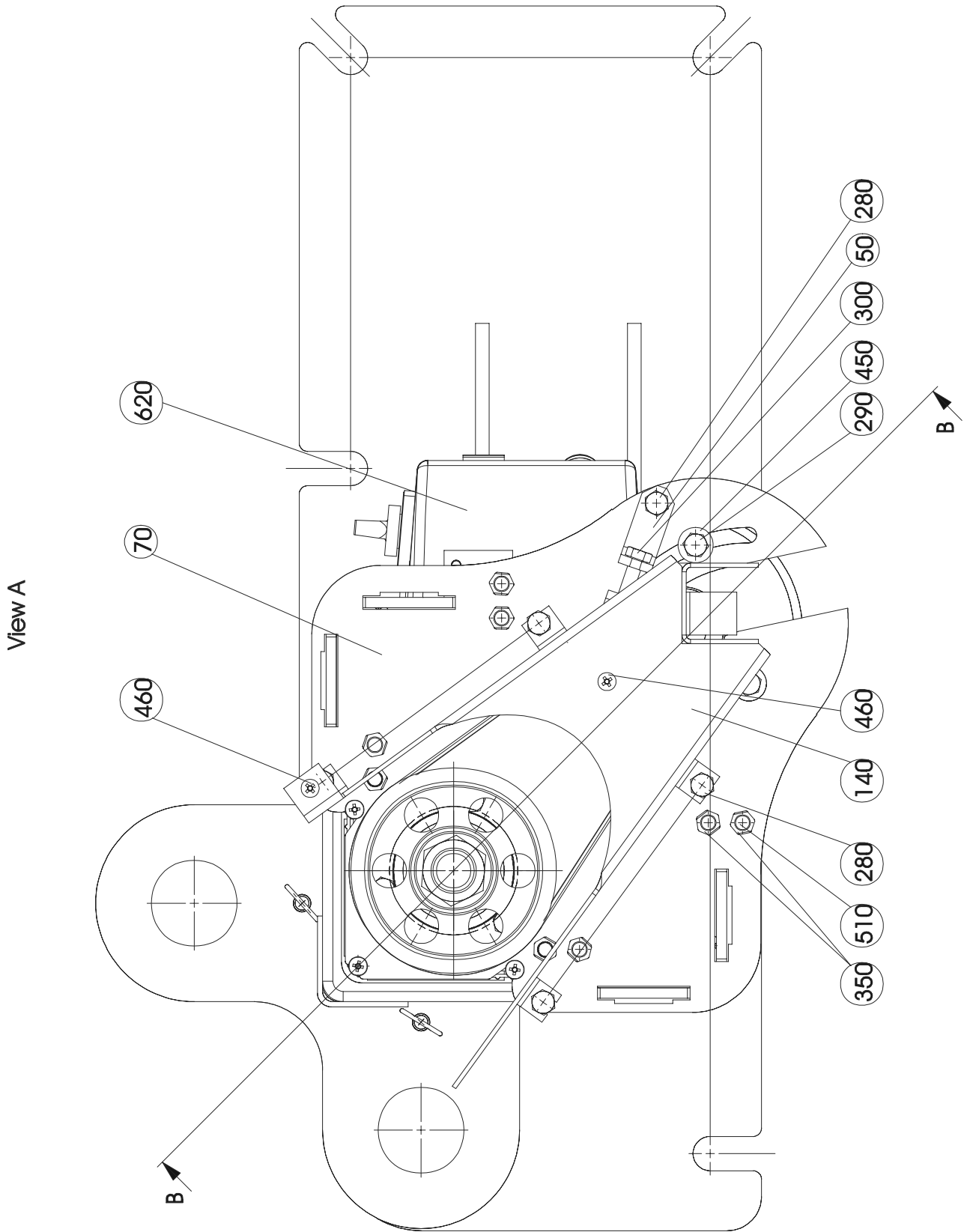

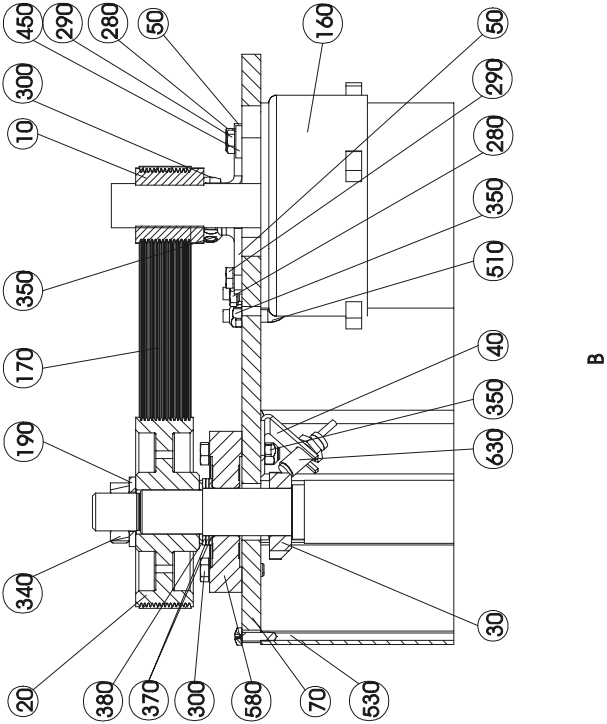
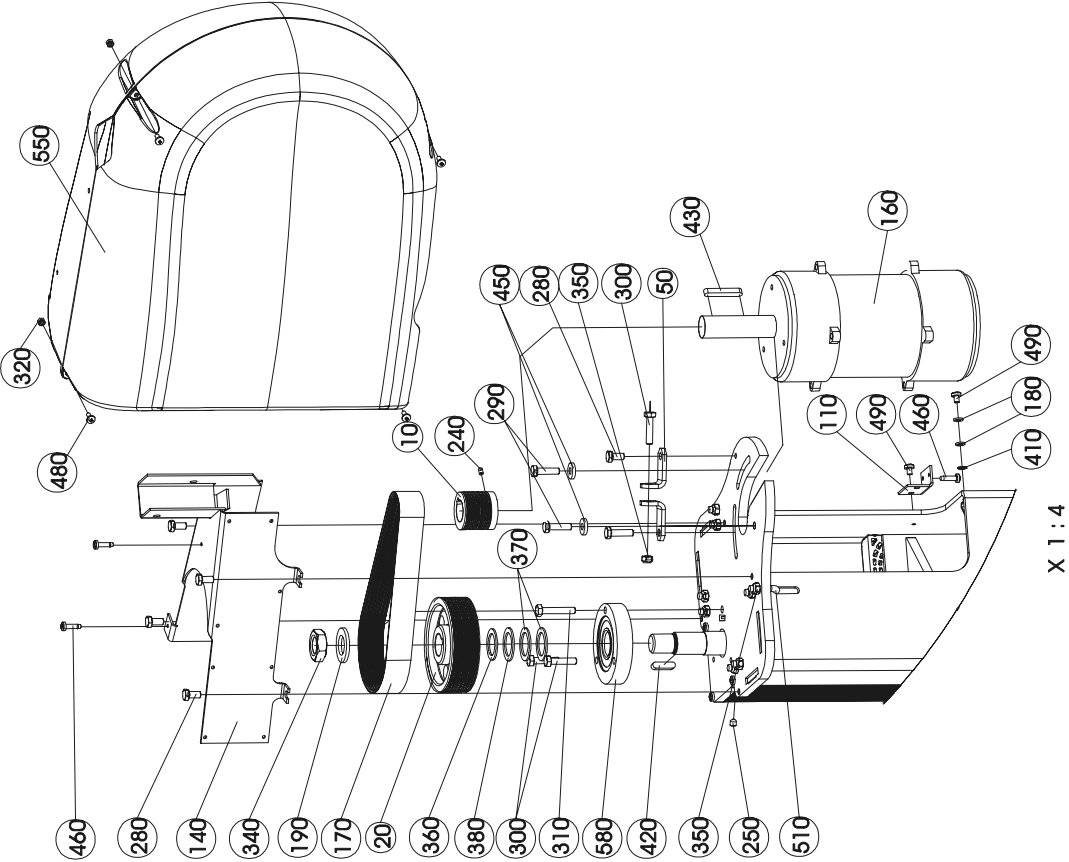

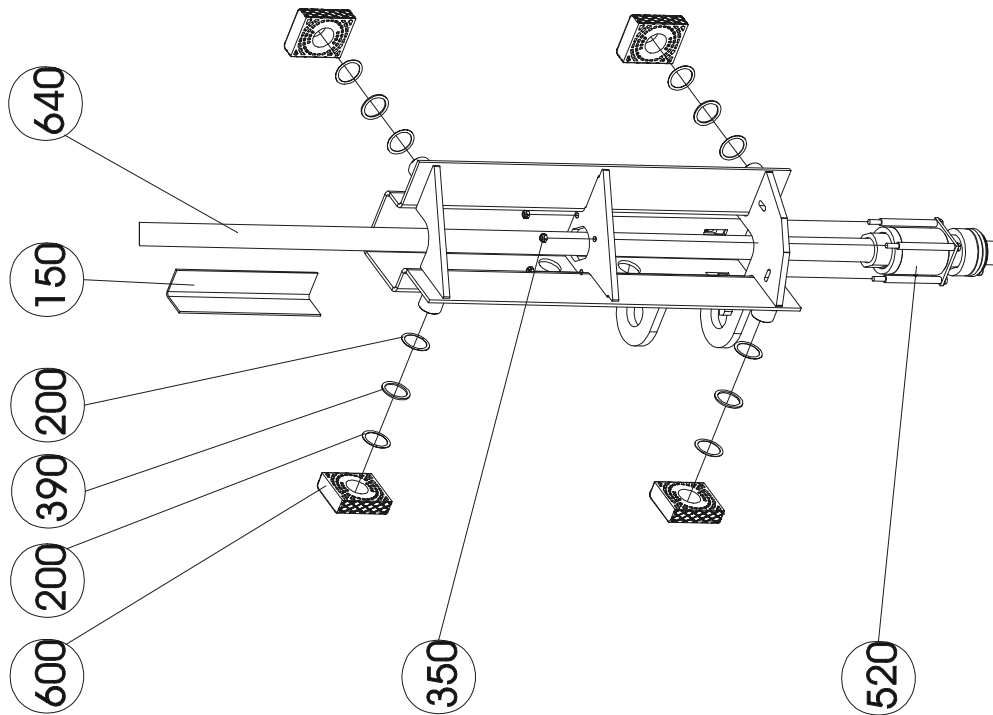
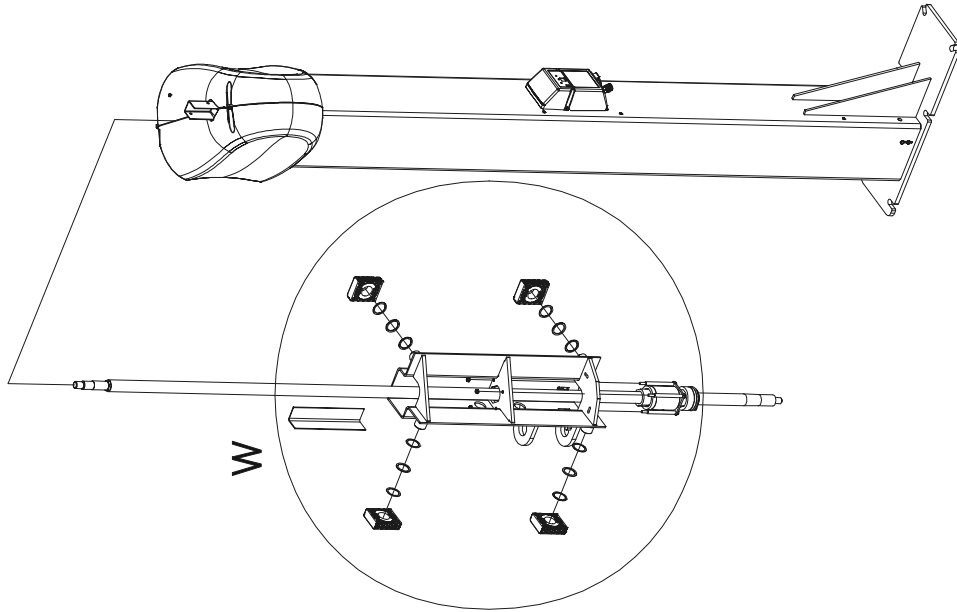

W 1 : 10

Item	Part #	Description	Specification
10	02 47 5240	Pulley	Rd. 50 44 lg.
20	02 47 5245	Pulley	Rd. 120 41 lg.
30	02 47 5270	Pulse Generator	
40	02 47 5290	Angle	
50	020470 00001800	Belt Tensioner	Sh. 70x20x5
60	020470 00001	Protective Insert	
70	020470 00006500	Motor Plate	Sh. 288x288x12
80	020470 00007000	Leaf Spring	
90	020470 00013700	Angle	Sh. 77x25x2.5
100	020470 00014400	Latch Release Rod	Rd. 10 280 lg.
110	020470 00014500	Angle	Sh. 57x40x2.5
120	030470 00004400	Carriage	
130	030470 00007200	Operating Column	
140	030470 00007700	Holder	
160	20 7066 5	Motor CO 2.30E3	2.4 kW
170	20 9652	Ribbed V-Belt	PJ660; 14 Ribs, Poly V
180	22 0125 06 1	Washer	A6.4
190	22 0125 24 1	Washer	A25
200	22 0137 5040 5	Wave Spring Washer	
210	22 0705 10 1	Slide	A10
230	22 0912 08025 1	Allen Screw	M8x25-8.8
240	22 0914 05008	Threaded Pin	M5x8-45H
250	22 0914 08008	Threaded Pin	M8x8-45H
260	22 0933 06012 1	Hex Head Cap Screw	M6x12-8.8
270	22 0933 06020 1	Hex Head Cap Screw	M6x20-8.8
280	22 0933 08016 1	Hex Head Cap Screw	M8x16-8.8
290	22 0933 08030 1	Hex Head Cap Screw	M8x30-8.8
300	22 0933 08035 1	Hex Head Cap Screw	M8x35-8.8
310	22 0933 08045 1	Hex Head Cap Screw	M8x45-8.8
320	22 0934 05 1	Hex Nut	M5-8
330	51 3072	Proximity Switch, Inductive	M12 / 2 mm / Cable Length: 3.5 m
340	22 0934 2420 1	Hex Nut	M24x2-8
350	22 0985 08 1	Hex Nut	M8-04
360	22 0988 284020	Shim Ring	28x40x2
370	22 0988 304220	Shim Ring	30x42x2
380	22 0988 304225	Shim Ring	30x42x2.5
390	22 0988 405025	Shim Ring	40x50x2.5
400	22 1481 03016	Dowel Pin	3x16
410	22 6798 064 1	Serrated Washer	A6.4
420	22 6885 080730	Feather Key	A8x7x30
430	22 6885 080750	Feather Key	A8x7x50
440	22 7337 05016	Blind Rivet	A5x16
450	22 7349 08 1	Washer	8.4
460	22 7504 04819 1	Self-Drilling Screw	4.8x19
470	22 7504 05522 1	Self-Drilling Screw	5.5x22
480	22 7985 05012 1	Flat Head Screw	M5x12-4.8-H

CO 2.30E3

490	22 7985 06008 1	Flat Head Screw	M6x8-4.8-H
500	22 9021 06 1	Washer	A6.4
510	23 0170	Fastening Bow	M8-8.8
520	030470 00016500	Load and Safety Nut Assembly	
530	23000011	Screw Drive Cover	
540	23000025	Cable Cover	
550	23000024	Cover Hood CO 2.30E3	
560	23000015	Gear Segment	
570	23000026	Pressure Spring	
580	24 8015 000	Flange Bearing	BE 72-30
590	24 8016 000	Flange Bearing igubal	
600	31 6068	Slider Block	10x83x30
610	31 5050	Cap Plug	
620	53 2644	Cap Plug CO 2.30E3	Ø40
630	51 3073	Proximity Switch, Inductive	M12 / 2 mm / Cable Length: 0.5 m
640	23 4770 001	Screw Drive	
650	23000032	Key Ring	

1.5 General View

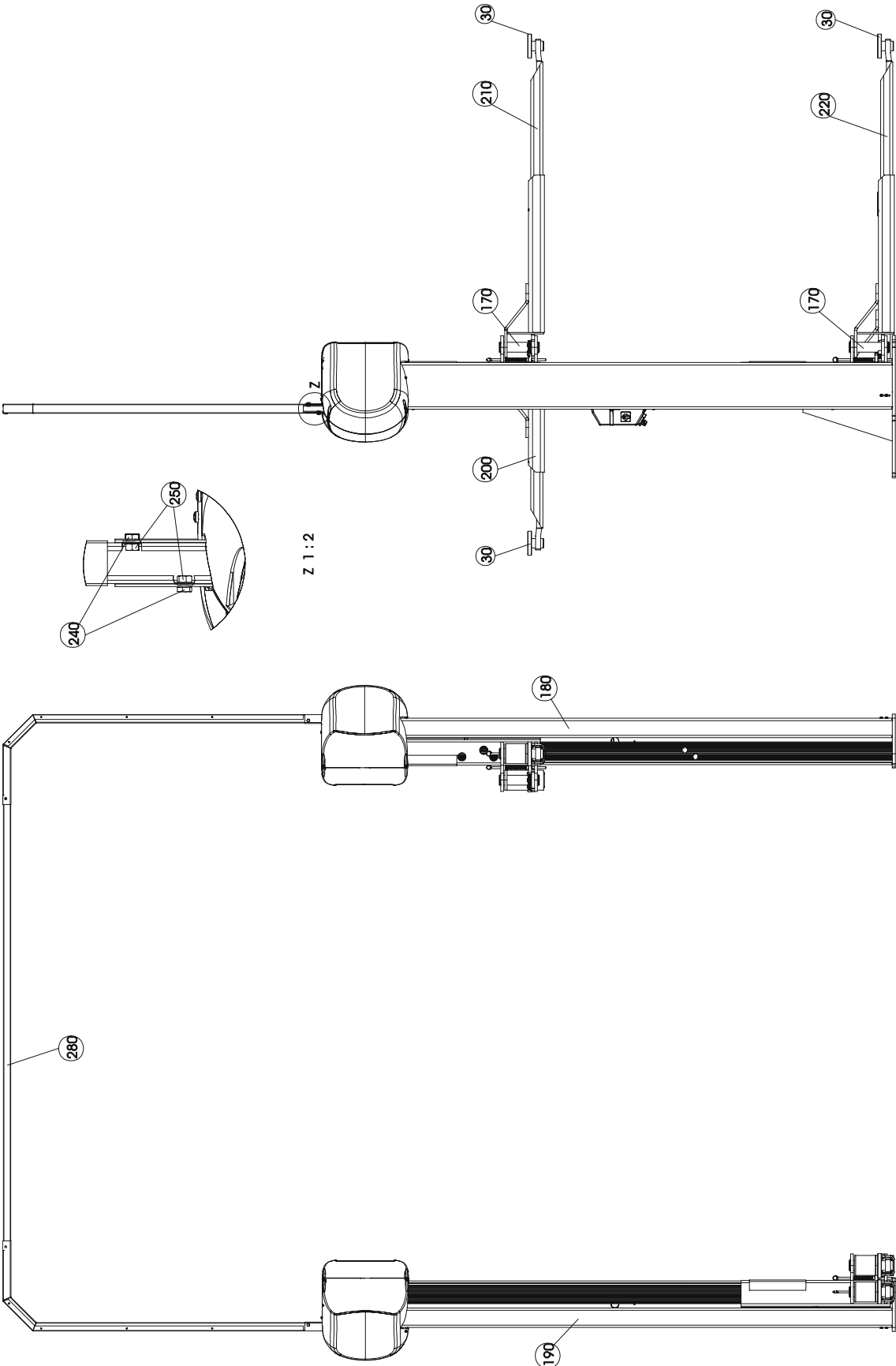

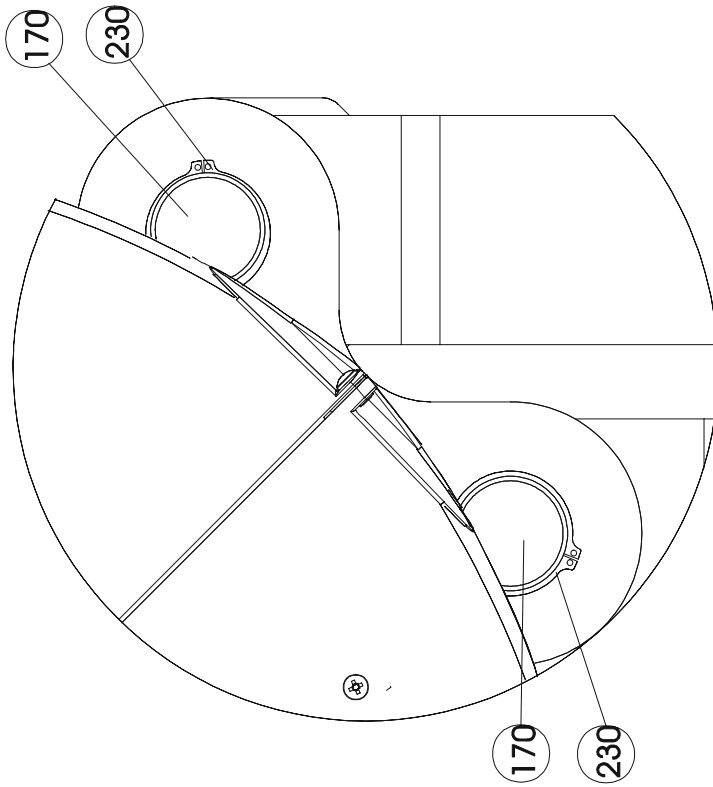

Y 1:2

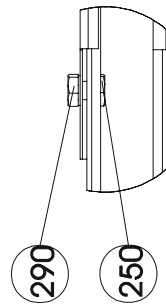
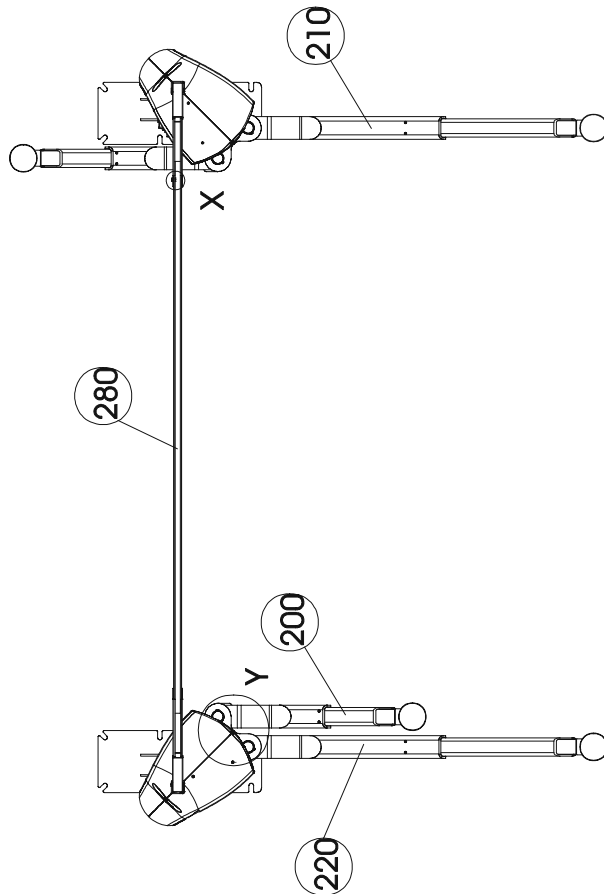

X 1:2

Item	Part #	Description	Specification
30	03 36 26390	Support Disk 60	
170	020470 00014300	Arm Pin	
180	030470 00007400	Operating Column	
190	030470 00007600	Column	
200	030470 00008000	Support Arm	
210	030470 00008200	Support Arm	
220	030470 00008400	Support Arm	
230	22 0471 050 1	Snap Ring	50
250	22 0934 08 1	Hex Nut	M8-8
260	22 6912 10020 1	Allen Screw	M10x20-8.8
270	23000014	Toothed Washer	
280	23000020	Cable Guide	
290	22 0933 08010 1	Hex Head Cap Screw	M8x10-8.8